

2.00mm-Pitch Board-in Connector with Short Pin Terminal

molex

The 2.00mm-Pitch Board-in Connector with Short Pin Terminal, designed mainly for automotive applications, complies with major industry standards and features improved terminal pin position for better solderability on thin PCBs.

Features and Advantages

Larger wire accommodation

Adopts automotive wire specifications (FLRY 0.22mm², 0.35mm²)

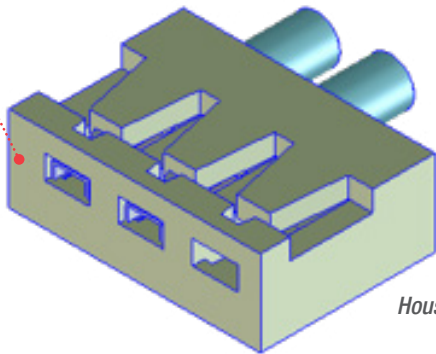

Housing (Existing)
35023

Crimp Terminal (Modified)

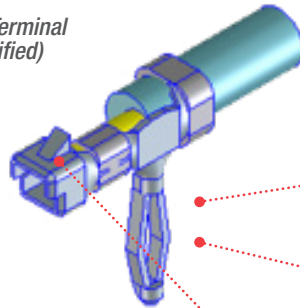

2.00mm-Pitch Board-in Terminal

Wider pin terminal

Enables better PCB retention force on PCB hole diameter of 0.90mm

Shorter pin terminal

Establishes good soldering condition for PCBs with a thickness of 1.20 or 1.60mm

Terminal and housing locking features

Ensures secure terminal retention force

Compatible with existing housing (35023), 0.90mm PCB hole and pattern

Allows existing Board-in Connector customers to retain their current PCB pattern

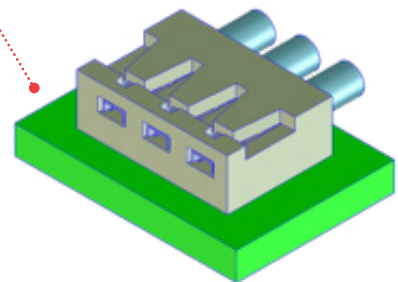
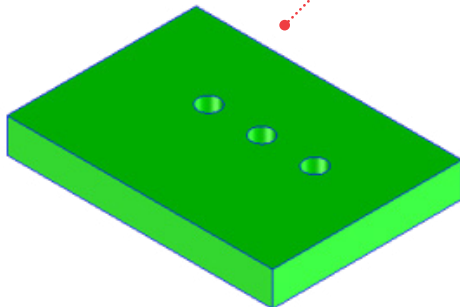

After Assembly

2.00mm-Pitch Board-in Connector with Short Pin Terminal



Markets and Applications

Automotive

- Infotainment
- Automotive lighting

Medical

- Patient monitoring

Industrial

- Factory machines
- Power tools
- Security systems

Home appliances

- HVAC systems
- White goods



Power Tool



Automotive Infotainment



White Goods



Automotive Lighting



Factory Machines



Security systems

Specifications

REFERENCE INFORMATION

- Packaging
- Terminal: Reel
- Housing: Bag
- Designed In: Millimeters
- RoHS: Yes
- Halogen-Free: Yes

ELECTRICAL

- Voltage (max.): 125V
- Current (max.): 2.5A
- Contact Resistance (max.): 10 milliohms
- Dielectric Withstanding Voltage (rms): 1000V AC
- Insulation Resistance (min.): 100 Megohms

PHYSICAL

- Housing: Polyamide (natural), ivory
- Terminal: Brass (pre-plating)
- Applicable Wire: FLRY 0.22mm², 0.35mm²
- Wire Size (AWG): 24, 22

- Plating:
- Contact Area: Tin-plated
- Operating Temperature: -40 to +110°C

Ordering Information

Custom Product	Description	Packaging
Contact Molex	2.0mm-Pitch Board-in Connector Terminal(Shorter Pin)	Reel (15Kpcs/reel, 90Kpcs/6reels)

www.molex.com/link/boardin.html

Molex is a registered trademark of Molex, LLC in the United States of America and may be registered in other countries; all other trademarks listed herein belong to their respective owners.